

ModEva™ 15T

ModEva is a range of numerical control units intended specifically for sheet metal working. Depending on the software installed, ModEva can be used on synchronized or non-synchronized press-brakes of the up-stroking or down-stroking type.

ModEva numerical control units can control up to 18 axes of which 2 are synchronized hydraulic axes especially intended for press-brakes.

The numerical control is composed of 2 main elements:

- The programming console.
- The CNC (Computerized Numerical Control).

The programming console is located within the operator's reach, generally fixed to a swiveling arm; the CNC is placed inside the electric cabinet.

The CNC is available in 2 rack formats.

- Rack version **C** (Compact): This is a small, very compact rack, convenient for many situations.
- Rack version **M** (Medium): This is a bigger rack permitting a varied combination of configurations.

The software enables manufacturers to configure the axes, the inputs/outputs and the auxiliary functions according to their needs.



Versions

PS	Version for synchronized press-brakes.
PC	Like the PS but for press-brakes with mechanical (or hydraulic) stops and beam control with a linear encoder.
ModEva CNC /C	ModEva CNC version "C" (Compact): can control up to 4/6 axes or even 18 with CAN axes*.
ModEva CNC /M	ModEva CNC version "M" (Medium): controls up to 12/14 axes or even 18 with CAN axes*.

* see definitions of the axes and configurations further on in the document.

ModEva Range

ModEva is a modular range with a choice of:

- 1 programming console 15" touchscreen.
- 2 programs (2D or 3D) and 1 Windows XP emb. operational system.
- 2 different rack sizes depending on the number of axes and the desired technology (analog or CAN).

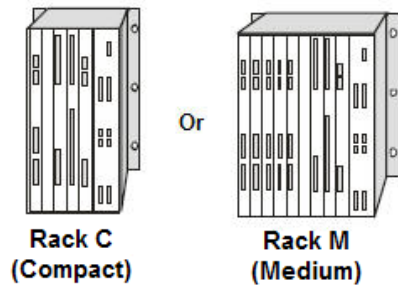

Definitions:

- Hydraulic axes:** An analog axis especially intended for controlling the beams (Y1-Y2). These two axes are on the NPU.
- Analogical axes:** Axes for which position is given by an incremental sensor and instructions are provided by the CNC via a $\pm 10V$ DC analog voltage. One also corresponds to an analog interface axis. These axes are controlled by boards called NMX / NSX. Each of these boards controls 2 axes.
- CAN axes:** Axes for which positioning information is handled through a CAN bus. These axes require an NCX board on the CNC side and a CAN interface on the servo-amplifier side. An NCX board can control up to 8 axes. The number of CAN axes is controlled as an option. The ModEva CNC can be equipped with a maximum of 2 NCX axis boards.
- NMX:** A master board for 2 analog axes. A master board controls up to 3 NSX slave boards.
- NSX:** A slave board for 2 analog axes. A slave board in all cases requires an NMX board.
- NCX:** CAN board for a maximum of 8 CAN axes. This board can handle various protocols according to the type of servo-amplifier used. It is possible to combine CAN and analog axes.

Configurations of CNC axes

Rack version	CNC / C (Compact)		CNC / M (Medium)					
No. of axis boards	2		5					
Axis position (slot No)	0	1	0	1	2	3	4	5
The most common configurations	NMX	-	NMX	NSX	NSX			
	NMX	NSX	NMX	NSX	NSX	NSX		
	NMX	NLR	NMX	NSX	NSX	NLR		
	NCX	-	NMX	NSX	NSX	NLR	NMX	
	NCX	NLR	NCX	NLR			NMX	NSX

Configuration of the consoles

Console	S-MOD-15T
TFT screen	15"
Touchscreen	Yes
Resolution	1024 x 768
Ext. keyboard socket	Yes, PS2
Ext. mouse socket	Yes, serial mouse with mini DIN socket
Power	Through the panel link
Seal	IP 54
Link CNC	2 cables RJ 45 twisted pair category 6. Cables 5 m or 10 m. Dist. > 10 m with CYBELEC repeater.
Temperature, pollution level, relative humidity, during work.	Min. 5° Celsius, max. 40° Celsius.* Pollution level 2. Relative humidity (10 to 85% non-condensing). * If the ambient temperature approaches or exceeds 40° Celsius, it would be advisable to install special ventilation, or even air-conditioning.
Weight	Approximately 9.6 kg

Configuration of the CNCs



Reference	S-CNC-xxxxPxxxx
Software	2D or 3D
System	Windows XP embedded, XP pro optional**
CPU	500 MHz
RAM	256 MB, 512 MB optional**
Disk	4 GB flash**
Network	Yes, Ethernet RJ45
USB 1.1	Yes
Printer port	Yes
Keyboard input	Yes, PS2
Mouse input	Yes, PS2
Screen output	Yes, std VGA
Y1, Y2	NPU board
RS 232 port	Yes, 2 (of which 1 configurable to RS 422)
Serial port for PLC	Yes, RS232 configurable to RS 422
Analog axes	NMX, NSX boards, according to configuration and rack version
CAN axes	NCX boards, depending on configuration and rack version
Sensor inputs	5V DC line driver, obligatory complementary signals
Digital inputs	NIN boards, 32 24 VDC opto-coupled inputs
Digital outputs	NOT boards, 32 outputs, 24 VDC "sources", max 2.5 A / output (NOT 204). Max 6 A / board
Analog inputs	NIN boards, 6 analog inputs Depending on configuration 0-10, 0-24 VDC A/D 8 bits
Analog outputs Axes and FA	NOT boards, 4 outputs, 0-10 VDC (8 bits) for the auxiliary functions, Z _{out} output impedance < 100 Ω , ZI load ≥ 10 kΩ
Power supply	24 VDC / max 4A ± 15%
Seal	Must be installed in an approved electric cabinet.
Temperature, pollution level, relative humidity during work.	Min. 5° Celsius, max. 40° Celsius.* Pollution level 2. Relative humidity (10 to 85% non-condensing). * If the ambient temperature approaches or exceeds 40° C, it would be advisable to install special ventilation, or even air-conditioning.
Weight	Rack version C: approx. 5 kg. Rack version M: approx. 6 kg. Depending on equipment

** Data may be modified without notice for the proper operation of the numeric control.
Other configurations available on request.

Auxiliary axes and functions of the standard software

The elements listed below are available and can be configured in all numerical controls supplied with standard software (within the number of available axes).

Y1 - Y2	Synchronized axes for the beam (servo-valves, proportional valves).
X, X1, X2, X5, X6	Main rear backgauge axes (X5, X6 generally for gauges external to the frame).
X1 ABS, X2 REL	Secondary gauge axes in absolute or relative mode.
R, R2, R5, R6	Backgauge height-adjustment axes (R5, R6 generally for gauges external to the frame).
Z, Z2, Z5, Z6	Axes for left/right movement of the backgauge.
M1, M2	Axes for the adjustment / movement of the die.
Conical folds	Comfortable programming for conical folds (requires X, X2 and adapted stop fingers).
Free 1, 2, 3, 4	Independent axes without any particular control.
Pressure	Voltage output for pressure valve control. Should current control be wanted, the MVP 100 accessory, which is an external amplifier module to be fitted in the electric cabinet, would be necessary (see the MVP 100 data sheet).
Crowning	Voltage output for adjusting the hydraulic crowning. Should current control be wanted, the MVP 100 accessory, which is an external amplifier module to be fitted in the electric cabinet, would be necessary (see the MVP 100 data sheet). or 24 VDC (SP, SN) outputs and potentiometric position transducer for adjusting the mechanical crowning (Wila type).
F1 to F10	Configurable auxiliary functions (possibly, the number of AFs may be limited according to the type of function and management). 24VDC voltage or logical order outputs, with or without position control by means of a potentiometric transducer. Special controls for gauge fingers, bending aids, die movements.
Languages	French, German, English, Italian, Spanish, Portuguese, Swedish, Danish, Finnish, Dutch, Hungarian, Polish, Czech, Slovene, Russian, Turkish, Chinese, Taiwanese. Other languages available on request.
Angle measurement	Automatic correction by means of the angle measurement in serial link with digital angle protractor Mitutoyo or other compatible systems.

Optional auxiliary axes and functions and other options (at extra cost)

M1 M2 mounting	Axes for the adjustment / movement of the die in relation with the choice of tool mounting.
X3, X4, X7, X8	Front gauge axes (not calculated).
Z3, Z4, Z7, Z8	Front gauge axes (not calculated).
H, H2	Rear sheet support axes (not calculated).
H3, H4	Calculated front sheet support axes.
AP1-AP4	Calculated front / rear folding assistance axes.
CAN axes	The number of CAN axes is optionally controlled.
Angle measurement	Option permitting the adaptation of an angle-measuring system during the folding.
Thickness measurement	Option permitting the automatic correction of the depth calculation by using external sheet-metal thickness measuring equipment connected by RS 232.
Axis thickness measurement	Option permitting the automatic correction of the depth calculation by using external thickness measuring equipment connected to an axis board. The measurement is taken using conventional encoders.
Message interpreter	Option for the complete remote control of the CNC via network or RS 232. Reading/writing of variables, corrections, part loading, mode changing, etc. Ideal for automation and/or applications with robot. Possibility of connecting the results of an external program.
Other	Various options exist and are specific to each OEM. Other options can be developed according to needs.

Hardware options

Designation	Description	Ordering number
Auxiliary panel	Auxiliary panel for Lazer Safe commands, virgin or customized auxiliary panels	S-OPT-BTAUX-S/E
Keyboard support	Support for external USB keyboard (<i>the keyboard is not provided</i>).	S-OPT-KBSUP15
Earthing kit	Rail and bridles for earthing the sheathing for the ModEva CNC rack. See illustrations below.	S-OPT-EARTHKITC for size C rack S-OPT-EARTHKITM for size M rack
CybVA 6	Interface board for proportional Hoerbiger valves and pressure + crowning valves.	S-CAH-CybVA6
MVP 100	Voltage / current conversion module (0-10V → 0,25-0,5 / 0-2 A) for pressure and crowning valves, to be fitted in the electric cabinet.	S-MVP-100/A
MSV 402	Voltage / current conversion module (0-10V → 0-50 mA, 0-300 mA) for servo-valves.	S-MSV-402/A

EC Directives

Directives

Our numerical control units comply with Directives EN 61000-6-4 / EN 61000-6-2.

Overall dimensions

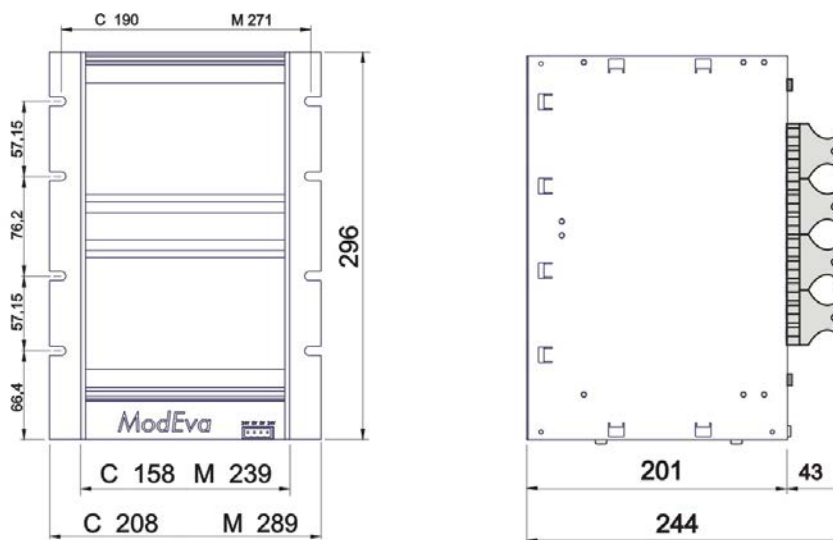

CNC / C

CNC / M

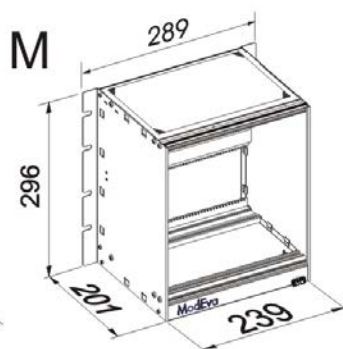
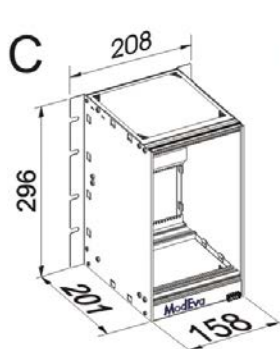

Earthing kit



ModEva 15T

